

Consumer & Industrial



WavePro LT
Installation and maintenance
manual



GE imagination at work

Warnings

Warning notices are used in this publication to emphasize that hazardous voltages, currents, or other conditions that could cause personal injury are present in this equipment or may be associated with its use.

Warning notices are also used for situations in which inattention or lack of equipment knowledge could cause either personal injury or damage to equipment.

Cautions

Caution notices are used for situations in which equipment might be damaged if care is not taken.

Contents

Description	Page
1. System overview	2
1.1 Service Condition	2
1.2 Major parameter and configuration	2
2. Installation	5
2.1 Busway Installation	6
2.2 Installation of bus plug	10
2.3 Installation of terminal box	10
2.4 Installation of the joint	11
3. Inspection	12
4. Maintenance	12
5. Busway installation checklist	13

1. System overview

Storage Notice:

Please check whether there is any damage in the transportation. If any, please inform the carrier immediately. If no damage, please store it with the package on until installation. Keep the storage environment tidy, dry and best near the installation place.

Please prevent the busway from impinge against, prevent contact the caustic liquid, gas, dust or beton. The unsuitable storage and convey can bring on serious damage and make the expiration date invalid.

NOTE: None busway is water-repellent before integrated and accurately installed.

1.1 Service Condition

1. 1. 1 The altitude should not be higher than 2000m;
1. 1. 2 The ambient temperature should not be lower than -5°C and greater than $+40^{\circ}\text{C}$, the average temperature within 24 hours should not be greater than 35°C ;
1. 1. 3 There is no obviously shaking and impact vibration in site;
1. 1. 4 The air should be free from exploding risk, metal corrosion, insulation damage gas or dust;
1. 1. 5 There should be no rain or snow invading in site.

NOTE: For more information of service condition, please refer to “6 Service condition” in IEC 60439-1 2004

1.2 Major parameter and configuration

1. 2. 1 major parameter

- rated working voltage: 690V/415V
- rated insulation voltage: 1000V/690V
- rated working current:

100A、160A、200A、250A、400A、500A、630A、800A、1000A、1250A、1350A、1600A、2000A、2500A、3150A、3800A、4000A、4500A、5000A

- rated working frequency: 50/60Hz
- Insulation resistance:

Within the ambient temperature of $+20^{\circ}\text{C}$ and the relative humidity of 60%, the resistance of each busway should be more than $20\text{M}\Omega$ before installation. However, it is allowed be less than $20\text{M}\Omega$ due to higher humidity or dewing.

- dielectric strength

Each busbar has to go through a Hi-pot test 3750V/ 5S before leaving factory.

- Short circuit capacity

Copper conductor

Rated current (A)	Rated short-time withstand current (kA)	Rated peak withstand current (kA)
250~400	15	30
630~800	30	63
1000~1600	50	105
2000~2500	65	143
3150~5000	100	220

Aluminum conductor

Rated current (A)	Rated short-time withstand current (kA)	Rated peak withstand current (kA)
100~250	10	17
400~500	20	40
630~800	30	63
1000~2500	50	105
3150~4000	80	176

1. 2. 2 Configuration:

1.2.2.1 Busway is composed of bus bars, insulation material and closed housing. The section is shown below.

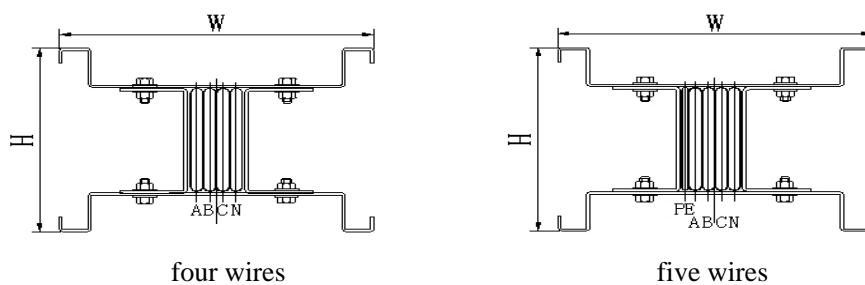

Fig. 1.1

Aluminum busbar

current (A)	Width W (mm)	Height H(mm)	Weight of busbar	
			Four-wire (kg) 100%N	Five-wire (kg) 100%N, 50%Pe
100~250	128	87	6.7	7.0
400	128	97	7.7	8.1
500	128	107	8.3	8.7
630	128	117	9.0	9.5
800	128	137	10.7	11.3
1000	128	152	11.5	12.2
1250	128	182	14.2	15.2
1350	128	197	15.0	16.2
1600	128	217	16.9	18.3
2000	128	257	20.1	21.7
2500	128	307	24.5	26.6
3150	128	459	33.6	36.7
3800	128	549	40.7	44.5
4000	128	589	44.0	48.1

Copper busbar

current (A)	Width W (mm)	Height H (mm)	Weight of busbar	
			Four-wire (kg) 100%N	Five-wire (kg) 100%N, 50%Pe
250	128	77	9	9.5
400	128	87	11.5	12.3
630	128	92	12.5	13.4
800	128	102	15	16.2
1000	128	112	16.9	18.4
1250	128	127	20.9	22.7
1350	128	142	23.9	26.2
1600	128	157	27.7	30.4
2000	128	187	34.7	38.1
2500	128	262	51.8	58.3
3150	128	339	62.6	69.3
3800	128	389	74.5	82.5
4000	128	409	79.3	87.9
4500	128	499	99.9	110.8
5000	128	539	109.6	121.6

1. 2. 2. 2 Physical data of plug (L×W×H) mm



Fig. 1.2

	Current	Physical data of plug (L×W×H) mm
Manual operating mechanism	100~160A	450×240×260
	250A	550×260×280
	400A	650×300×300
	630A	750×340×320
	800A	1000×370×340
Rotary operating mechanism	100A~160A	450×240×(300+50)
	250A	550×260×(320+50)
	400A	650×300×(340+50)
	630A	750×340×(360+50)
	800A	1000×370×(380+50)
Rotating crank operating mechanism	100A~160A	450×310×300
	250A	550×330×320
	400A	650×370×340
	630A	750×410×320
	800A	1000×440×340

2.Installation

Pre-Installation Procedure

- ✓ When possible, deliver busway to its installation location before unpacking.
- ✓ Large labels on each shipping carton or crate designate the items contained.
- ✓ Additionally, each busway piece is identified with an item number label. Make sure to install all the busways according the blueprint unless the engineer instructs locally.
- ✓ Inspect each busway piece for possible damage or contamination. Contact surfaces must be clean. However, do not attempt to polish tarnished contact surfaces.
- ✓ Check to ensure that joint insulators are not damaged or cracked and are firmly in place.
- ✓ Make insulation resistance test for each piece before installation.
- ✓ All the screw down moment should according to below form, excepting the bolt in the joint.

	M10	M12	M14	M16	M20
Screw Down Strength	17.7~22.6	31.4~39.2	51.0~60.8	78.5~98.1	156.9 ~196.2

2.1 Busway Installation

2.1.1 Horizontal Installation

- Horizontal through-the-wall installation

For dimensions of through-the-wall installation, please refer to the following figure.

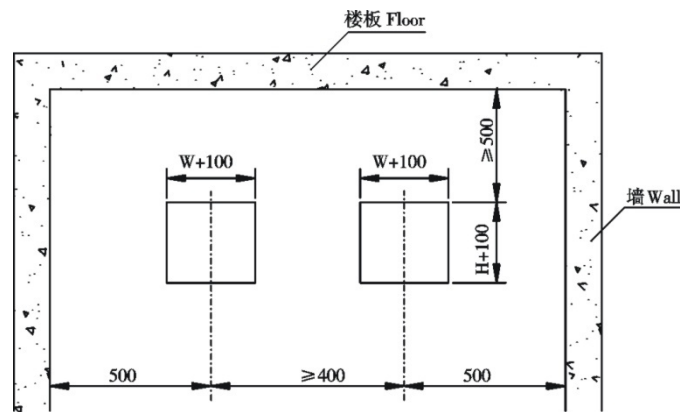

Fig. 2.1

- Horizontal installation-trapeze hangers overhead support

Holes shall be first drilled in the floor so as to inlay steel expansion bolts (holes may also be drilled on the spot for flexible installation) or pre-bury steel object for welding with hangers. The distance between two adjacent hangers shall not exceed 2m. Please specify your special requirements in order. There are two forms of horizontal installation. Please refer to the following figure.

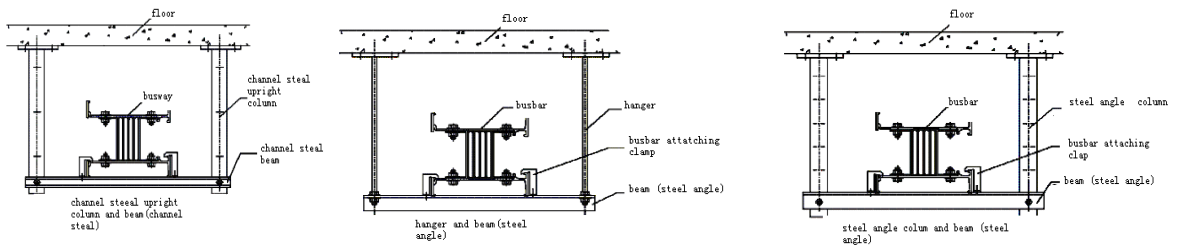

Fig 2.2

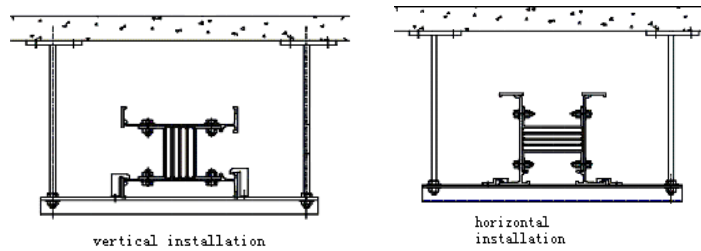

Fig 2.3

- Horizontal installation-wall support

Pay attention to linearity of the installation hole (i.e. the entire run of supports shall be installed at the same level at the same level). For installation types, refer to the graphic representation.

Horizontal installation along the wall may also contain vertical and horizontal installation.

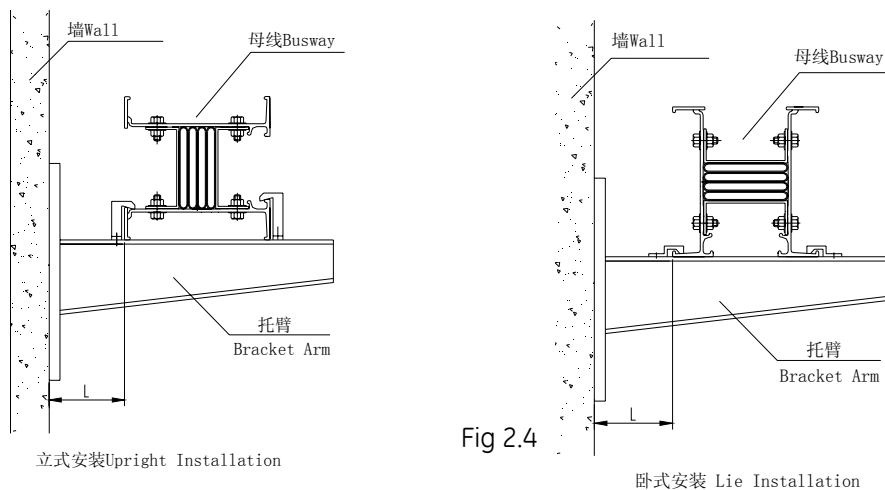

Fig 2.4

There are vertical and horizontal installation styles in this method.

Rated Current of Plugs (A)	100	250	400	630	800
L (mm)	150	195	210	230	260

Key points in horizontal installation

- ✓ When busway is placed horizontally, its distance from ground should be more than 2.2m, except for those in electricity-dedicated rooms (e.g. distribution room, electromotor room, electric shaft room, interlayer etc).
- ✓ The distance from wall should be more than 0.1m, and that from upper floor, ceiling floor and beam botton should not be less than 0.1m.

- ✓ Center distance between two neighboring parallel busways should not be less than 0.35m and it should not be less than 0.1m from board.
- ✓ Joint should be outside of the wall.

2. 1. 2 Vertical installation

For installing vertical bus run, please refer to the fig. For dimension of cut holes. It shall be ensured that the spacing between every two runs of busway exceeds 400mm if there are two or more than two vertical runs of busway installed in the same silo. Please refer to the Fig. below :

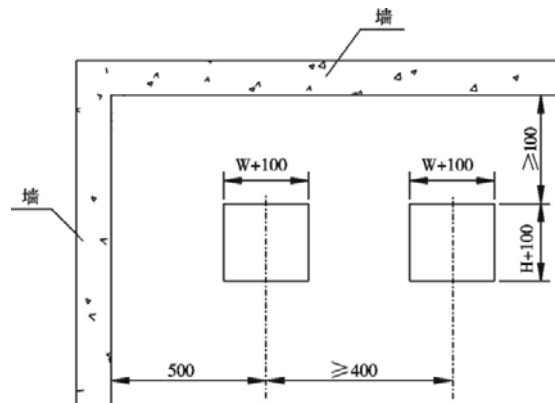

Fig 2.5

When choosing the spring hangers, the elastic force should be adjusted to $(G+F)$ kilogram (G is the weight of busbar between each floor while F is 5~10 kilograms which refer to the on-site condition). There are mainly three types of installation:

- A. Two types for front installation of spring hangers. Please refer to the Fig 2.6.

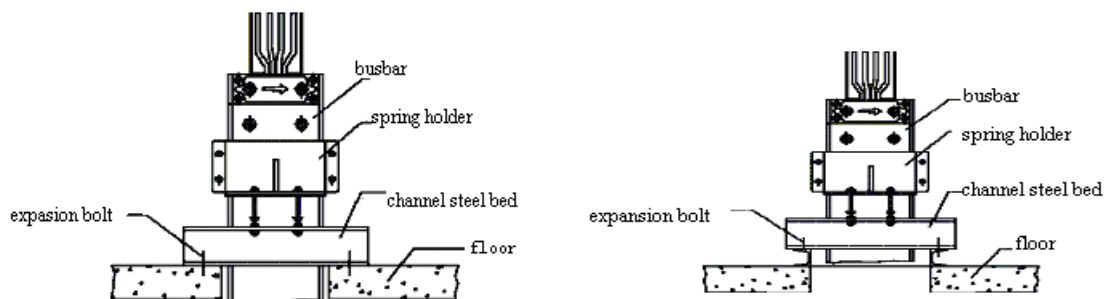

Fig 2.6

- B. Two types for side installation of spring hangers. Please refer to the Fig 2.7.

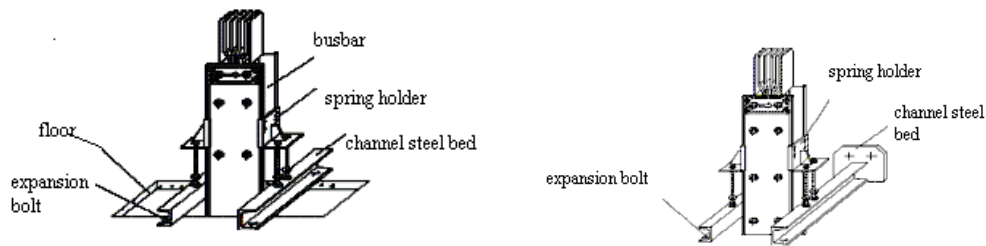

Fig 2.7

After placing the length of busway through the floor, follow this procedure to assemble hangers to the busway :

1. Loosen the hanger bolt A,
2. Assemble the hangers to each side of the busway.
3. Position the hangers on the busway so that the base channel rests on the floor or other support.
4. Fit the hanger clamps to the busway housing and hand tighten the hanger bolts
5. Anchor the base channels to their supports.
6. Tighten the hanger bolts
7. Install the next length and make the joint assembly (see the instructions for joining lengths below).

Key points in Vertical installation

- ✓ In vertical installation, the distance between joint and ground should not be less than 0.7m, while distance between busway and wall backwards should be more than 0.1m.
- ✓ Busway installed in riser should be reinforced in the center (generally when the space between floors exceed 4m or according to the user' special requirements), which may be carried out referring to the figure. The additional supporters is related with busway rating..
- ✓ In vertical installation, spring bracket should be installed first and then busway, together with the spring bracket, can be fixed on the channel steel bed. Switch the spring to adjust the nut so that bracket spring can naturally bear the weight of busway.

- ✓ The central distance between two neighbor vertical busways should be more than 0.35m, while the side distance should be more than 0.1m.
- ✓ The joint should not be located at the area across the floor.

2.2 Installation of bus plug

2. 2. 1 Before installing bus plug, the safety protection plate at the outlet has to be opened.

2. 2. 2 Before installing bus plug, breaker has to be in the off position.

2. 2. 3 After installing bus plug, plug should be locked tightly with the fixed framework.

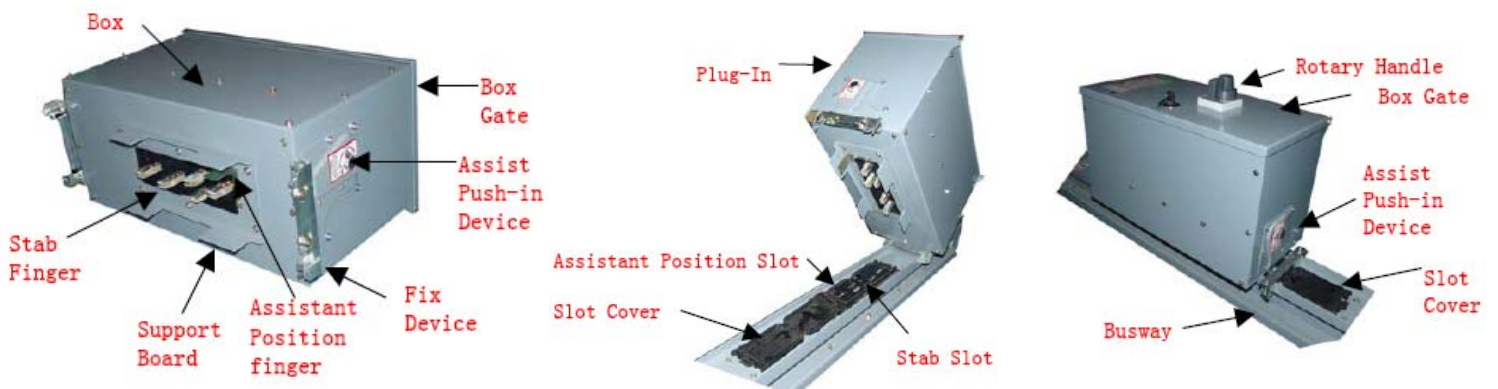

Fig 2.8

2.3 Installation of terminal box

The reinforcement of the end tap box installed in riser maybe carried out referring to the Fig 2.9.

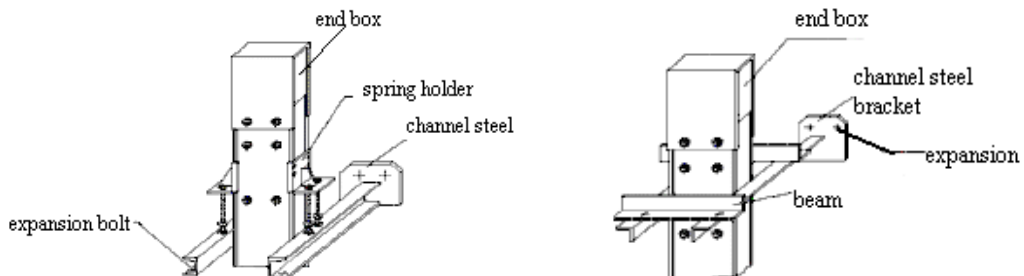

Fig 2.9

2.4 Installation of the joint

The joint adopt a kind of “intension mnemonic” bolt. It has a intension tag which helps to notice the position.



Fig 2.10

2. 4. 1 Make the two busway face to face, and put apart 40~50mm between them.
2. 4. 2 Insert the joint between the two busway, and screw down the bolt until the first cap be cutted and the tag drop.
2. 4. 3 When the installation work interrupted, all the joint and busway ends should be covered by plastic to prevent it form water or dust.

Notice: Don't use wildness force when inserting the joint. Please use a wood or rubber mallet to hit it when needed. Never use a hammer or hard thing to hit it.

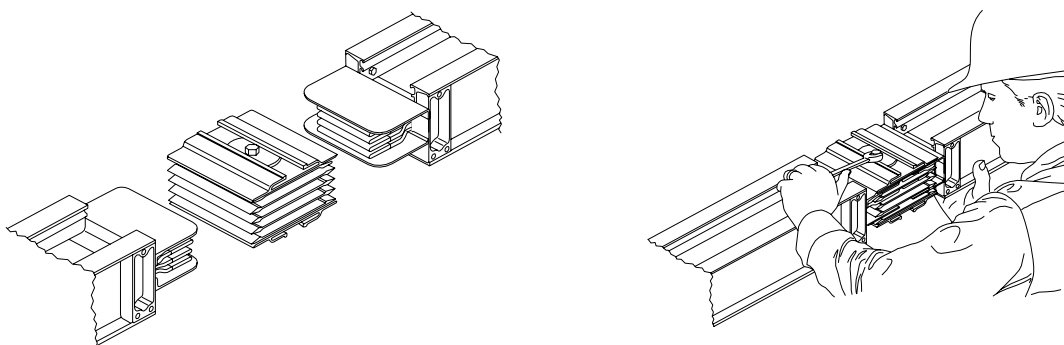

Fig 2.11

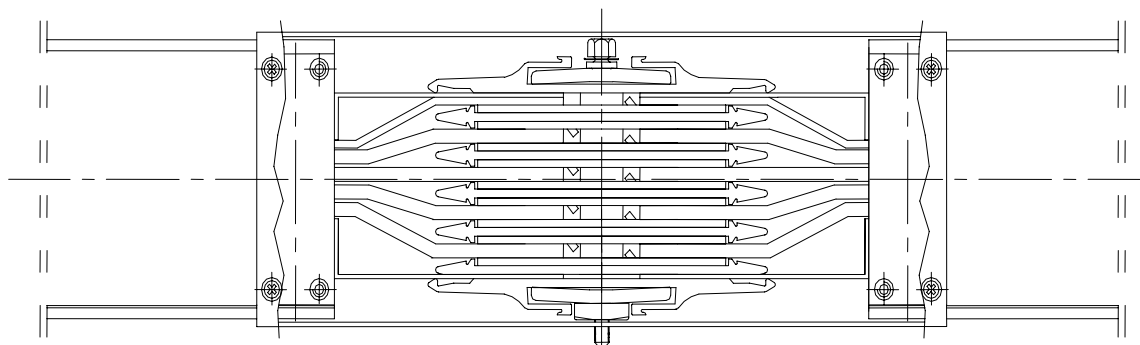

Fig 2.12

3. Inspection

- During the operation, every section of busway should be measured & recorded the resistance data. If the resistance data is less than $M\Omega$ or biggish fall. Should adjust or reinstall until the data is ok.
- When the installation is all completed, the insulation resistance value of the whole system should not be less than $20M\Omega$ (Between phases, between phase and grounding terminal). But in the higher humidity area, the insulation resistance can be less than $20M\Omega$ some time after the installation.
- Make sure the insulation resistance is not less than $0.4M\Omega$ before voltage on. If resistance value is less than $0.4M\Omega$ but over $0.1M\Omega$, run the bus system without load for 4~16 hours, Then run with load. If insulation resistance is less than $0.1M\Omega$, the system should be OFF to analyze the reason and modify the failure.
- Before connection, check for correct phasing of the conductors and ensure no cross-phasing.
- The busway and all plugs have to be inspected every three years.
- Bus way system can not work with any load before transmitting electricity. Therefore, all plugs must be in off position.

NOTE: The whole busway has to do a mega test before energizing.

4. Maintenance

The busway, especially those with large noises, has to be inspected every year

- Check that the total load current should be no more than the main busbar current or the design current.
- Check for adverse temperature rise with infra-red thermometer.
- Check insulation resistance of the busway system and keep a complete record.
- Make sure the installation bracket is stable and the reliable connection of the joint bolt.
- Check if there is any rust and corrosion with components.
- Check the equipment close to busway that might cause damage because of external heating.
- Clean the outer surface of the shield..

5. Busway installation checklist

GE Job Number:

Customer ID:

Run Identification:

Amp Rating:

Service:

1. Was there any shipping damage? Report any minor damage or missing parts to the factory. Be sure to include the item number. No
2. Proper storage before actual installation.
 - a. Were bus components kept clean and dry? Yes
 - b. Were bus components exposed to corrosive fumes, liquids, salts, or concrete materials? No
3. Have you read this installation instruction book? Yes
4. Bus exposure during installation.
 - a. Were bus components kept clean and dry? Yes
 - b. Were bus components exposed to corrosive fumes, liquids, salts, or concrete materials? No
 - c. Was there any mechanical damage due to handling? No
5. Did each piece of bus get a pre-installation megohm test? (Individual pieces should megohm test as infinite resistance.) Yes
6. Mounting and support.
 - a. Is each 10 feet of bus run supported, including any vertical sections? Yes
(Closer supporting may be required, based on job specifications.)
 - b. Does any support interfere with a bus joint? No
 - c. Are any bus terminations to other equipment used as support? (Busway weight should not bear on equipment, such as switchgear, switchboards, or transformers.) No
7. Is the bus installed level and plumb? Yes
8. Was a periodic megohm test performed as this run was installed? (After every two or three items or as critical items are installed. Joints should be tightened for all megohm testing.) Yes
9. Has the bus been inspected for proper phasing? Yes
10. Are all joint bolts properly tightened to 50 lb-ft (68 N-m) torque? Yes
11. On vertically mounted bus using spring hangers, were the correct settings verified? Yes
12. Did you check for proper clearances for the bus at floors, walls, ceilings, other bus, and trades? Yes
13. Have all shipping screws been removed from expansion lengths? Yes
14. Was a final megohm test performed when all bus was installed? Yes

Note: Please list any exceptions made to this checklist and any other comments related to the installation of this run of bus:

This checklist is intended to insure a sound installation of GE busway. It is not intended to cover all items related to the installation, successful startup, and long-term use of the product and in no way relieves the contractor of his obligation to meet all specification and code requirements.

Installation Contractor

Signed

Date